

HOW-TO-BUILD GUIDE

CARPORT

WHAT YOU CAN BUILD USING THIS GUIDE

This guide will show you how to build a free-standing, open-sided single carport.

BEFORE YOU BEGIN BUILDING

Contact your local territorial authority and confirm that the height, type and location of the carport you intend to build comply with all local planning and building rules, and whether a building or resource consent is required. Where a consent is required construction drawings must be submitted to the building consent authority for approval before you begin construction.

PLANNING YOUR CARPORT

These outline instructions are for a 6.0 m long x 3.0 m wide x 2.4 m high free-standing timber carport with a long run metal mono pitch roof. It incorporates six posts and main beams along the side of the carport which are set to the pitch of the roof, to slope from one end to the other. The materials will need to be calculated based on the actual size and type of carport you intend to build.

MATERIALS

Posts	100 x 100 mm H5 treated radiata pine timber
Beams	250 x 75 mm H3.2 treated radiata pine timber
Rafters	150 x 50 mm H3.2 treated radiata pine timber
	250 x 50 mm H3.2 treated radiata pine timber
Roof underlay	heavyweight black building paper over galvanised netting
Roofing	long run factory-coated corrugate metal roofing with the manufacturer's recommended screw fixings
Flashings	two lengths of matched barge flashing and one length of soft-edged verge flashing
Bracing strap	25 mm galvanised mild steel strap with tensioners
Bolts	12 mm hot-dip galvanised steel bolts, nuts and washers
Joist hangers	150 x 50 mm stainless steel hangers
Nails	75 mm hot-dip galvanised jolt head nails
	100 mm hot-dip galvanised jolt head nails
Concrete	aggregate and cement pre mixed in bags
Slab concrete	ready mix concrete
Reinforcing steel	HRC 668 steel reinforcing mesh
Hardfill	concrete slab hardfill
Boxing	100 x 25 mm boxing timber
Braces/pegs	scrap timber

CONSTRUCTION

1. Confirm the location of your carport and drive a peg into the ground to mark one corner. Measure a distance of 6.0 m in one direction – this will be the long side of the carport, so ensure that you have the side aligned in your preferred direction. Drive a peg into the ground to mark the second corner. Measure out 3.0 m at right angles to the second peg and mark the ground with a temporary mark and then mark out another 3.0 m temporary mark at right angles to the first peg. Check that the distance between the two temporary marks along the length of the carport is 6.0 m (see Figure 1).
2. You will now have a 6.0 m by 3.0 m rectangle marked on the ground with two corners marked by pegs and two with temporary marks. To confirm that the rectangle is accurately marked out, measure diagonally from each peg to the temporary marks at the opposite corner – these dimensions need to be the same, so adjust the temporary marks until the diagonal dimensions are equal and drive a peg into the ground in place of the temporary marks. Double check your measurements to ensure that the distance between each peg at each side of the rectangle is 6.0 m and the width of the proposed carport is 3.0 m (Figure 1).

Posts

3. The structure has three posts along each of the long sides, cast into concrete footings. You will need to dig 900 mm deep x 400 mm diameter or 400 mm square holes at each corner peg and another hole midway up the sides of the carport in line with the corner holes. Use the corner pegs as the mark for the centre of the post holes and run a string line up the side to align the central hole and mark it with a peg. (Figure 1)
4. Cut six 100 x 100 mm timber posts to 3.55 m in length and after placing 100 mm concrete in the bottom of the holes, insert the posts and brace them vertically with temporary braces and pegs. (Figure 2)
5. Check that the posts are plumb and square and that the outside dimension over the posts across the carport is 3.0 m, and along the carport is 6.0 m, and that the diagonal dimensions between the corner posts are equal. You may need to adjust the temporary braces to achieve this. Once you have confirmed that your post setout is accurate, firmly nail off the temporary braces.
6. Place more concrete into each hole and tamp with a length of timber to compact the concrete to a level 100 mm below the finished ground level. Water the dry mix in accordance with the instructions on the bag. Allow seven days for the concrete to cure.

Beams

7. Measure up from the ground 2.4 m on one post at the intended higher end of the carport and mark this point. Do the same at 2.2 m above the ground to the post at the intended lower end of the carport. Do this on one side of the carport only. Using a string line, level these two marks across to the same posts on the other side of the carport and mark the level off. Next, run a string line along each long side of the carport from the low mark to the high mark and mark this line on the central post. These marks denote the position of the underside of the side beams, which will be installed on a 200 mm slope over the length of the carport, to form a pitch to the roof which will facilitate water run off. (Figure 3)
8. Cut two 250 x 75 mm timber beams to 6.1 m in length. Put a mark 50 mm in from each end of the beams to allow a 50 mm overhang of the beams to each corner post. The end cuts will need to be in line with the vertical post when the beam is fixed to the posts on the 200 mm fall line (from 2.4 m to 2.2 m).
9. Erect the beams to the two long sides of the carport by temporarily nailing the beam on the outside of the posts. The beams should be aligned with the marks on the three posts along each side and have a 50 mm overhang at each end. You may want to install temporary support blocks on each post to sit the beam on while it is nailed in place.
10. Drill two 12 mm holes through the beams at each post – the holes should be centred 50 mm down from the top and up from the bottom of each beam. (Figure 3)
11. Install 12 mm bolts with washers to each of the holes through the beam and the post, with the nut and washer on the inside face of the post. Cut off each of the posts in line with the top of the beam. (Figure 3)

Rafters

12. Seven rafters are installed to span across the carport from the inside face of one beam to the other. The rafters at each end are 250 x 50 mm to match the depth of the beams. The five intermediate rafters are 150 x 50 mm. The rafters at each end will be fixed between the beams on the outside of the corner posts, and aligned with the end of the beam that overhangs the post by the 50 mm thickness of the rafters. Mark the position of the five intermediate rafters at even centres between the end rafters, along the beams on each side of the carport. Nail a 150 x 50 mm stainless steel joist hanger to the beams at each of the intermediate rafter positions, ensuring that the hangers are located to align the top of the rafter with the top of the beam. (Figure 3)
13. Cut two 250 x 50 mm timber rafters with end plumb cuts (ie vertical cuts), and cut five 150 x 50 mm timber rafters to 3.0 m in length.
14. Position the two end rafters on the outside face of the corner posts at either end of the carport and aligned with the plumb cut on the end of and with the top of the beam. Nail through the face of the rafter with three evenly-spaced 100 mm jolt head galvanised nails into the corner post, and with two nails skewed through the face of the rafter into the beam.
15. Locate the remaining five intermediate rafters into the joist hangers on the beam and nail each rafter to the joist hanger. (Figure 3)
16. Check that the diagonal dimensions of the carport roof frame are equal and adjust to ensure that the roof is square and then nail a diagonal galvanised steel roof brace at each corner of the carport across the top of the rafters. After tensioning the roof braces and checking that the roof is square, nail the roof braces to each rafter they cross.

Roofing

17. Install the netting to the top of the rafters and stretch tight.
18. Install the building paper over the netting. Start at the bottom end and work progressively up the roof, laying the paper at right angles to the fall and with a 150 mm overlap. Fix as per manufacturer's instructions to the top of each rafter and beam. (Figure 4)
19. Measure and order the selected metal roofing to the correct length – allow for the roofing to lap as required and to align with the outside face of the beams at the high end and sides of the carport, and to overhang 200 mm at the low end. Fix according to manufacturer's instructions with screws or nails and sealing washers. Fixings generally go through the crest of the corrugate, not the trough. (Figure 4)
20. Install barge flashings to both sides down over the beams, ensuring a neat waterproof junction between the verge and barge flashings at each front corner. (Figure 4) Install soft-edged verge flashing over the roofing and down over the beam at the high point of the roof.
21. Remove the temporary braces from each corner post.

Note:

Local body bylaws may require the roof water from the carport be collected and drained – if this is a requirement, you will need to install a roof gutter to the rafter at the low end of the roof and connect this to drainage that complies with local body regulations.

Alternatively you may want to install a gutter and storage tank to collect the roof water.

Concrete slab

22. The parking space under the carport could be surfaced with loose metal or alternatively you may want to incorporate a concrete slab.
23. For a slab, erect temporary 100 x 25 mm wooden boxing along all sides of the carport on the line of the posts to a minimum height of 100 mm above the surrounding ground. Ensure that it is set level and well pegged to resist the weight of concrete when poured. (Alternatively you may wish to erect the boxing with a slight fall to one side or end of the proposed concrete slab to assist with rainwater runoff). (Figure 5)
24. Dig out the soil within the rectangle formed by the boxing to a level 150 mm below the bottom edge of the boxing and install a minimum of 150 mm of well compacted hardfill, to a line level with the underside of the boxing, to the entire area. (Figure 5)
25. Install HRC 668 steel reinforcing mesh to the entire area of hardfill. Sit the mesh on concrete packers or plastic chairs to ensure it will be located in the centre of the 100 mm concrete carport slab when poured.
26. Pour 100 mm thickness of 17.5 Mpa ready-mixed concrete over the entire area, ensuring that it is vibrated and screeded and trowelled to level and is aligned to the height of the top edge of the boxing. (Figure 5)
27. Allow the concrete to cure – keep concrete wet during curing using a mist sprinkler. After 3 days the boxing can be removed.

MORE INFORMATION

Refer to the New Zealand Standard for light timber frame construction, NZS 3604:1999 *Timber Framed Buildings* for more detailed information if your project varies from these instructions.

Figure 1

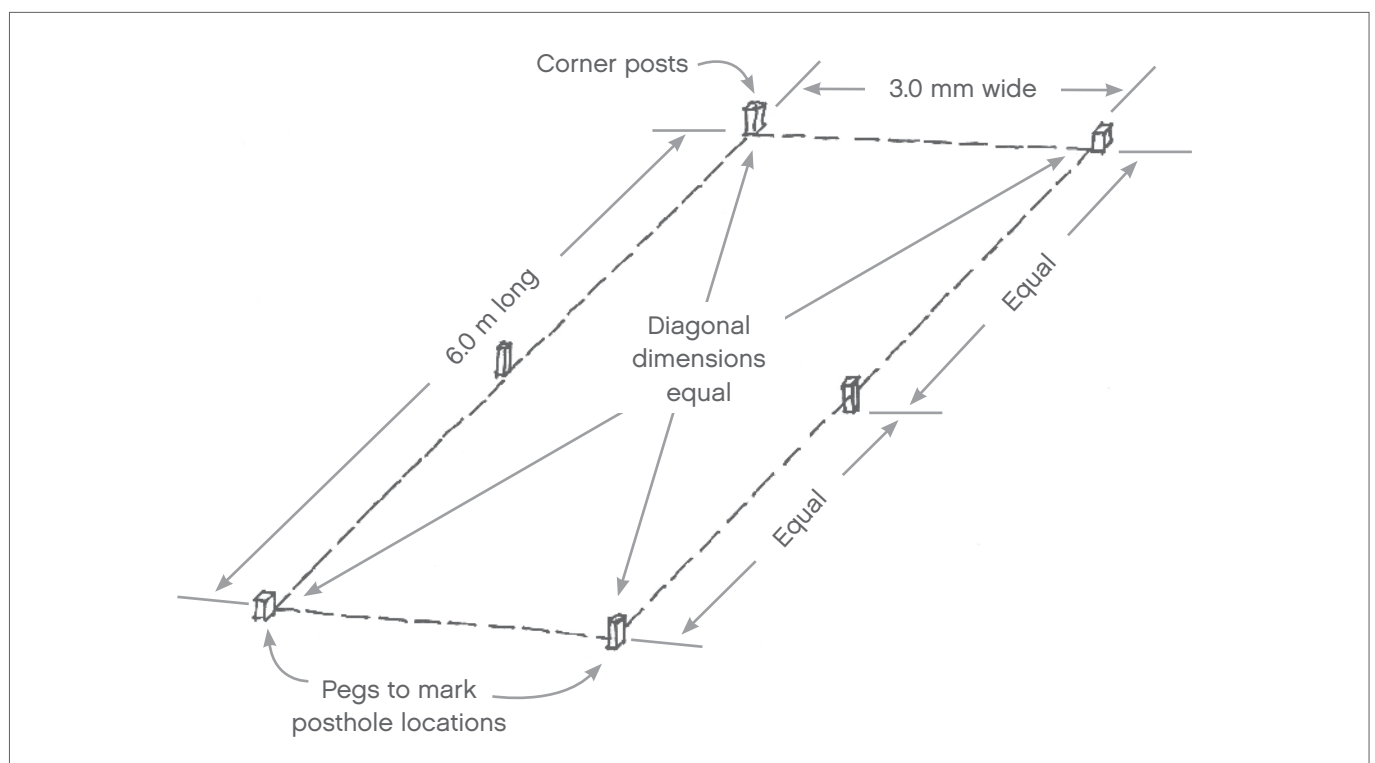

Figure 2

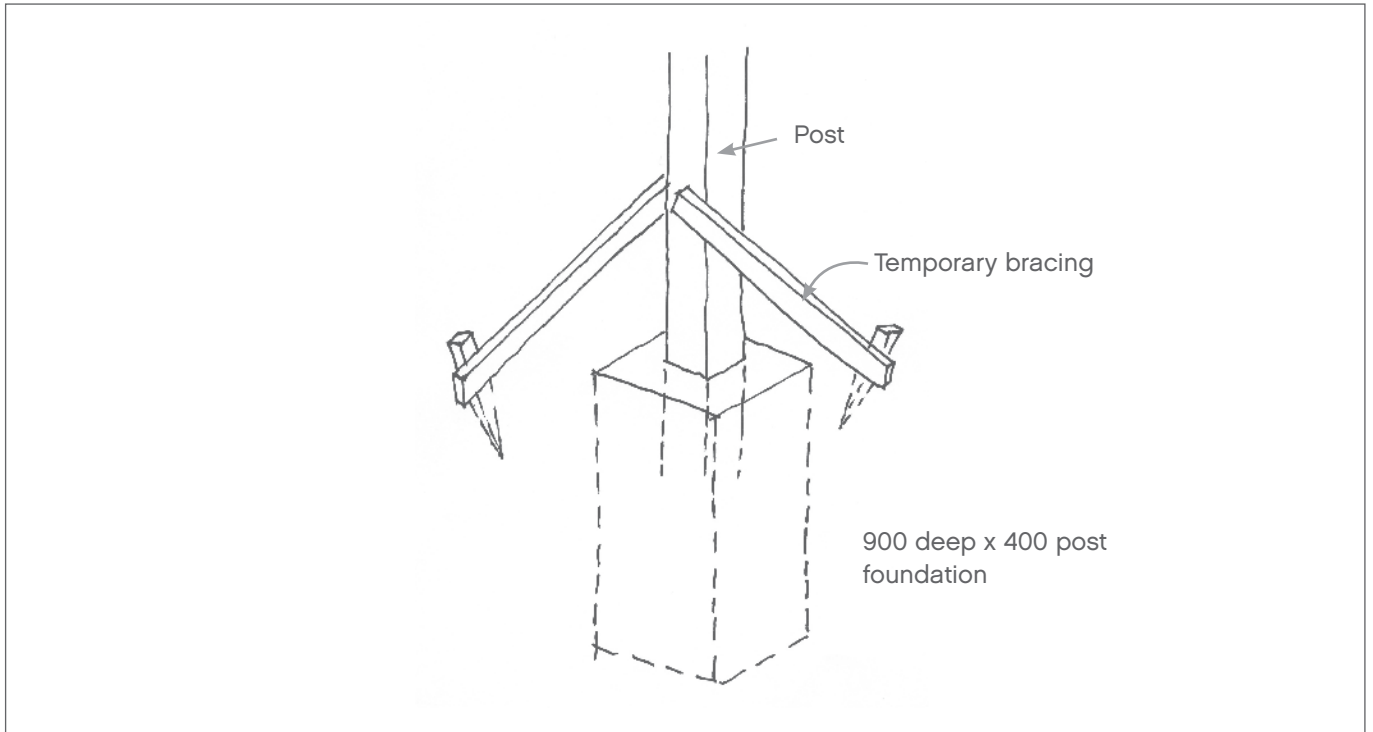

Figure 3

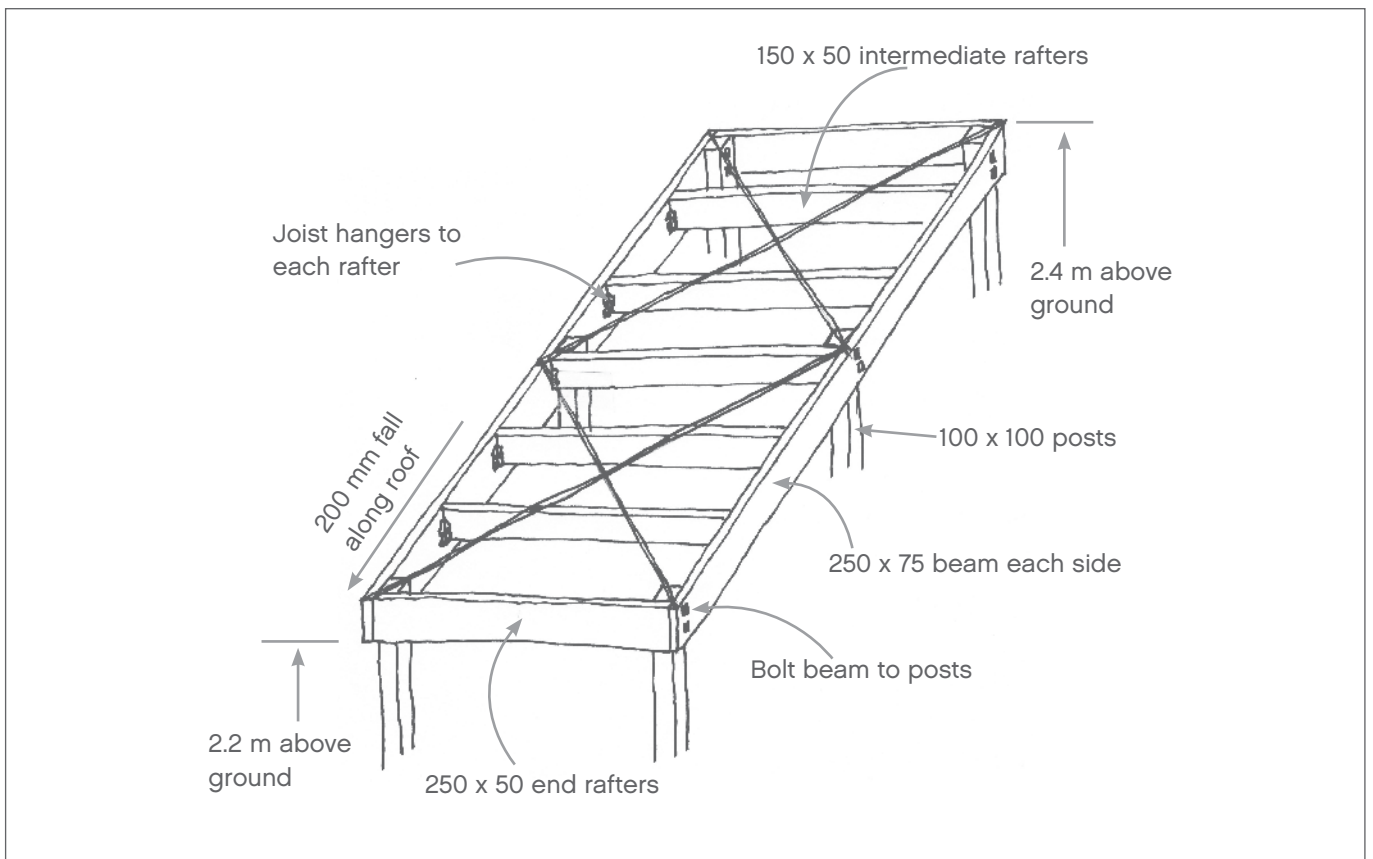

Figure 4

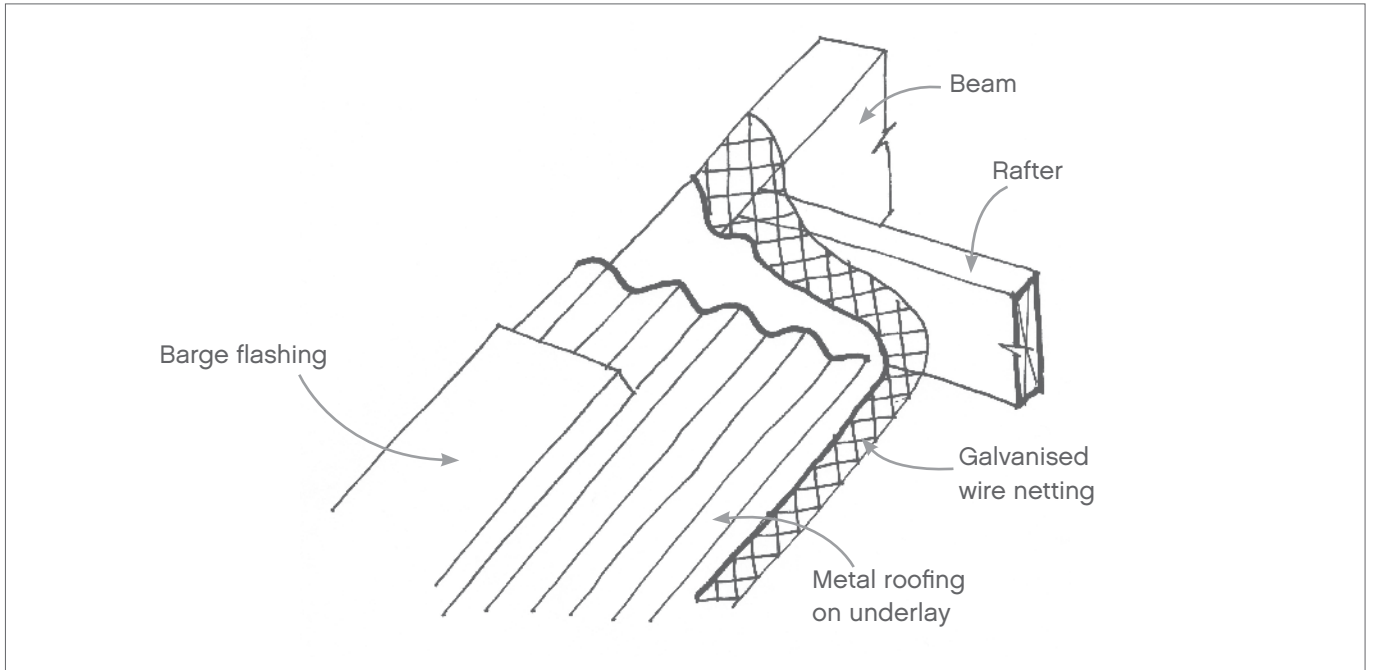
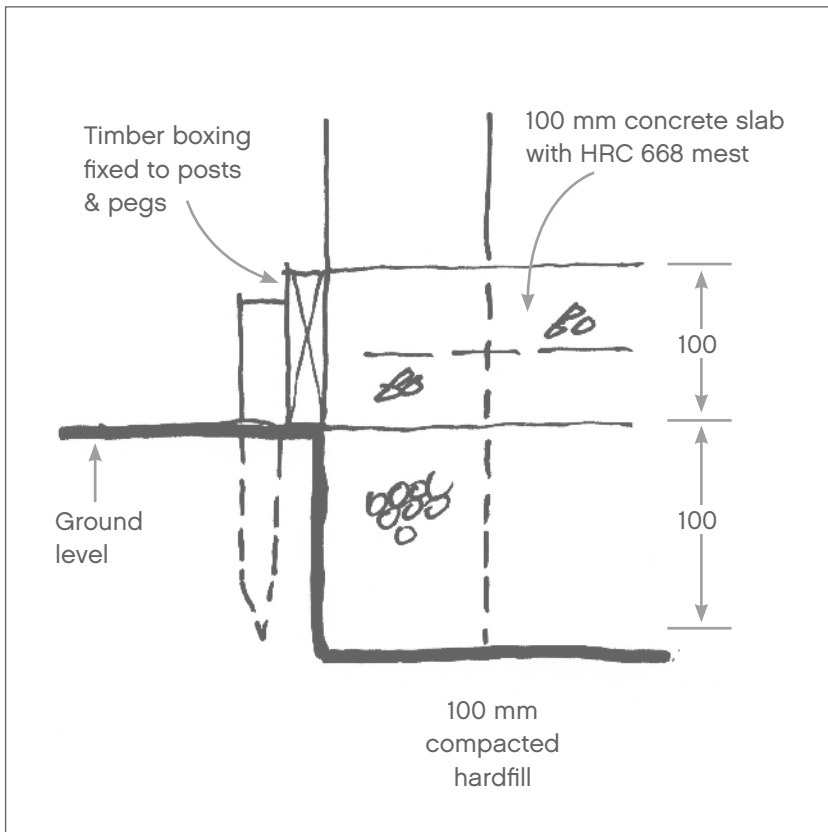

Figure 5



Disclaimer:

Woodco has taken reasonable care to ensure that the information and the facts contained on the website are accurate and any opinions given are fair and reasonable.

However, the website makes the information available to you as a general information service only.

The information contained on, or provided through, the website has not been prepared by taking into account the particular objectives, situation or needs of any individual users.

Accordingly, you should assess whether it is appropriate in light of your own objectives, situation and needs.

For that reason Woodco strongly recommends that you confirm any information that relates to a particular product.

Woodco also recommends you consult a professional before proceeding with any project or acting on any of the information or material provided on the website.