

# INFORMATION SHEET

# STRUCTURAL MATERIALS

## PLYWOOD JOINTS

The information provided below has been taken from the New Zealand Timber Design Guide 2007, published by the Timber Industry Federation and edited by Professor A H Buchanan. To purchase a copy of the Timber Design Guide, visit [www.nztif.co.nz](http://www.nztif.co.nz)

### PLYWOOD FOR STRUCTURAL CONNECTIONS

The method of joining plywood and timber components is a critical part of the economy of timber structures. Plywood is extremely useful in joining very large timber components together such as in gusset plates for portal frames or for trusses. Box beam ends can be efficiently joined to other members using plywood plates and cleats, provided that stiffening ribs are added to allow nailing in the supporting members as shown in diagram 1.

**Diagram 1: End fixings for box beams**

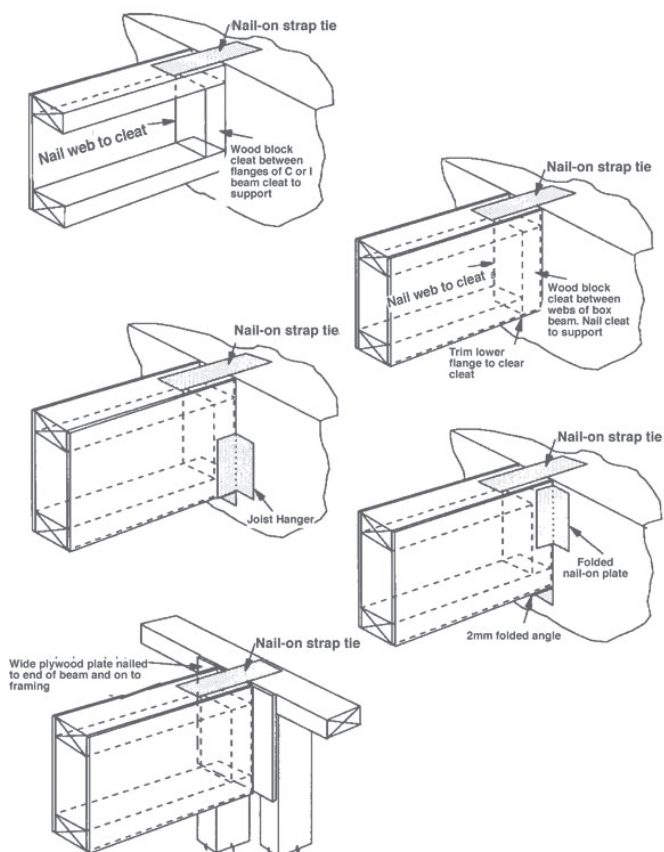

To fabricate web splices in the plywood, sometimes carefully machined and glued scarf joints are used but more often splice plates are lapped and glued on the web as shown in diagram 2.

Diagram 2: Alternative web splicing details

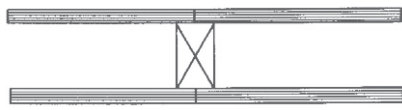

No splice

Web can be used in stiffness calculations but not strength



Single splice plate

Glued inside web and between flanges (hidden) or full depth visible on outside of beam

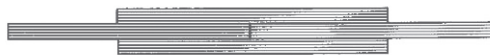

Double splice plates

glued as above

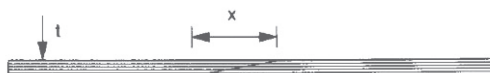

Factory glued scarf joint

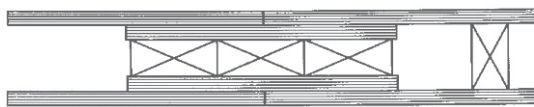

Nailed single splice

Timber backing for nailing, machined to allow for thickness of splice plates within beam cavity

Splice plates with thinner stiffening ribs allow a nailed or nailed and glued connection without changing the exterior dimensions of a beam or portal. Glued splice plates can be designed using NZS 3603 Appendix J. The webs in web beams are often not spliced, in which case the plywood web contributes only to stiffness, but is ignored in bending strength calculations, where only the properties of the flanges are used.

Plywood can be fastened with, nails, screws, power-driven nails, other mechanical fasteners, and with high quality controlled adhesives. Butt joints between plywood sheets must be located over framing members, or alternatively a tongue and grooved joint may be used to control movement normal to the surface. When butt jointing, a 2 mm gap should be left to allow for in plane movement in response to humidity changes. On factory profiled T&G panels, allowance is made for this movement in the joint designs. Close edge nailing can be achieved because of the cross-banded nature of plywood. The composition of plywood offers high resistance to pull through of nail heads. Staples are not recommended for structural joints because they are thin and prone to corrosion. Glued scarf joints have been used to make longer sheets but have caused problems when site glued.

Flat-head nails should be used in all load bearing joints especially where lateral loads are expected. Nails with brad or other small heads should not normally be used because the heads offer little resistance to pull through in cyclic loading. However, such nails are used to fix interior flooring when a clear finish is required and there is a low loading requirement. Screws set under the surface should be used in flooring, and roofing under membranes, to minimise nail popping. In green timber, or joints that may not remain dry in service, nails and screws should be hot dipped galvanised (or be of a higher corrosion resistance such as type 316 stainless steel).