

# HOW-TO-BUILD GUIDE

## LOW RETAINING WALLS

### WHAT YOU CAN BUILD USING THIS GUIDE

This guide shows you how to build a timber retaining wall up to 1.2 m high consisting of posts embedded in the ground and horizontal rails. It includes drainage behind the wall to prevent the build-up of water which could overload it. Suitable soil types for this type of wall are granular – such as firm gravel, stiff clay and sand or rock – or a mixture of these.

The wall detailed is not suitable for:

- walls higher than 1.2 m
- where the wall supports a driveway, parking area, the weight of a bank or building above the wall (see Figure 1) – in these cases you must have the wall designed by an engineer and a building consent obtained
- soil types such as very soft clays (when they are wet you can easily squeeze the clay between your fingers), peat, made-up ground, fill or topsoil.

For a low retaining wall, the posts must go 100 mm into the ground for every 100 mm retained above ground. Walls higher than 1.5 m will require a building consent.

For retaining walls 1 m or higher, the New Zealand Building Code may require a safety barrier at the top. In domestic situations this is likely to be required where the wall is beside an access path to the house.

### MATERIALS

- 150 x 150 x 2400 mm long timber posts treated against decay to H5 standard
- 150 mm diameter half round timber rails with squared edges, or 200 x 50 mm (180 x 42 mm finished) interlocking retaining wall planks, or 200 x 50 mm RS planks, all treated against decay to H4 standard
- hot-dip galvanised nails 150 mm long for half rounds or 100 mm long for planks
- stiff concrete mix with a strength of 17.5 MPa (or bagged pre-mixed concrete)
- drain coil – slotted PVC flexible drainpipe
- free-draining metal backfill
- geotextile fabric
- paint-on timber preservative
- timber for braces and pegs.

### CONSTRUCTION STEPS

#### Planning and measuring

1. Plan and measure the length and height of the wall. The spacing of vertical posts will depend on the size of post and rails used. A 150 mm square post can be placed at up to 910 mm centres (the 10 mm allows a fitting tolerance for an end-to-end joint between the horizontal members at the post position). If 200 x 200 mm square posts can be obtained the spacing can be increased to 1310 mm for 150 mm half round rails. Your supplier can advise on appropriate spacing.

#### Digging

2. Remove any topsoil along the line of the wall and dig out to a firm level foundation for the wall base. Cut back the face of the bank to allow for a space of at least 300 mm behind the back of the wall. Drive timber pegs in the ground at both ends of the wall and set a string line between the pegs to indicate the back of the wall. Measure for, and place pegs along, the string line to indicate the position (centre) of each post.
3. Start the holes by digging a 500 x 500 x 100 mm deep area around the post (this can later be backfilled with topsoil). Then use a post hole borer to dig 300 mm diameter holes so that the total depth is 1300 mm. Angle the borer to allow for the slope of the poles (1:10). Place about 100 mm of metal in the holes and then put the two end posts in place. Brace the posts temporarily in position so that they are vertical when viewed from the front, but slope towards the bank at 1:10. Fill the holes with concrete to within 100 mm of the ground level, rodding the concrete into place as necessary, and leave to set.

#### Set-out

4. Run string lines between the end posts at top and bottom and use these to line up the intermediate posts (see Figure 2.) Always pack the string line 10 mm off the post and used a 10 mm packer when positioning the intermediate posts – this stops a slightly out-of-line post affecting the string line. Note that it is best to avoid cutting the treated timber, but if it is unavoidable make sure that the cut end is not in the ground and treat all above-ground cut ends with a paint-on timber preservative. Provide temporary bracing and concrete the posts in place. When all posts are in position, leave two days for the concrete to harden.

#### Inserting posts

5. Place the horizontal rails to the back of the posts, starting at the bottom. Ensure rails are level, with butt joints only behind posts. Fix with one hot-dip galvanised nail at each post – 150 mm nails for half round rails and 100 mm nails for 50 mm thick planks. Stagger the end joints in the rails so that butt joints occur on alternate posts.

#### Backfilling and finishing

6. Lay 50 mm depth of free drainage metal along the bottom at the back of the wall. (See Figure 3.) Place the drain coil on top of the metal and lead the ends to where they can discharge into the open. If possible, have the drain coil accessible at both ends so it can be flushed out. Cover the drain coil with 250 mm of free-drainage gravel and overlay it with the geotextile fabric – this will reduce the silting up of the drain coil.
7. Continue to fill with drainage metal, ensuring that there is a minimum of 300 mm against the wall. The rest of the gap between the wall and the bank may be filled with well-compacted excavated material. The backfill and drainage metal can be kept separated by unrolling geotextile fabric as backfilling proceeds or by a rigid sheet of metal or hardboard or plastic which is slid up as the work progresses.
8. Finish backfilling 100 mm below the top of the wall and lay geotextile fabric across the top of the free-draining gravel. The top 100 mm may be filled with topsoil to assist plant growth (see Figure 3).

### MORE INFORMATION

Construction of this wall must comply with the requirements of New Zealand Building Code B1 Structure available free online at [www.dbh.govt.nz](http://www.dbh.govt.nz)

Figure 1

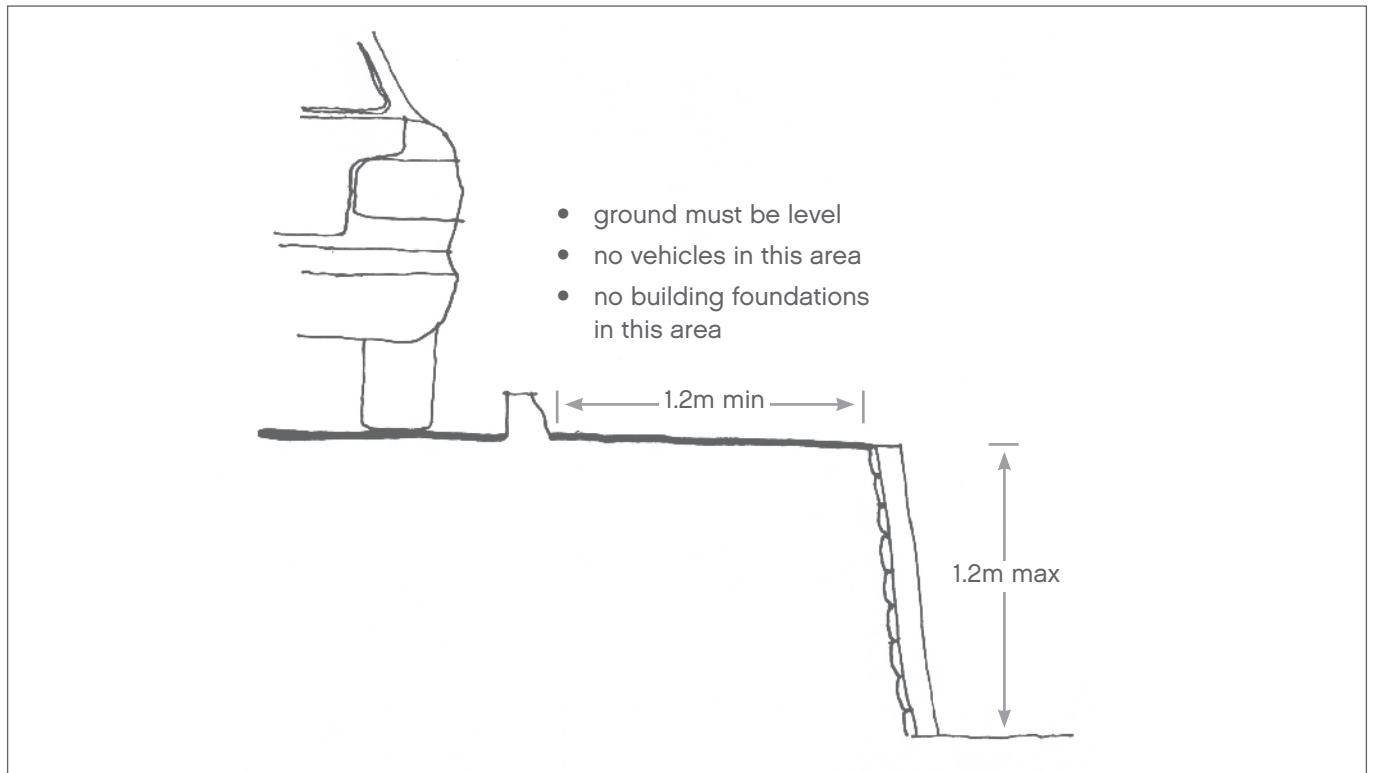

Figure 2

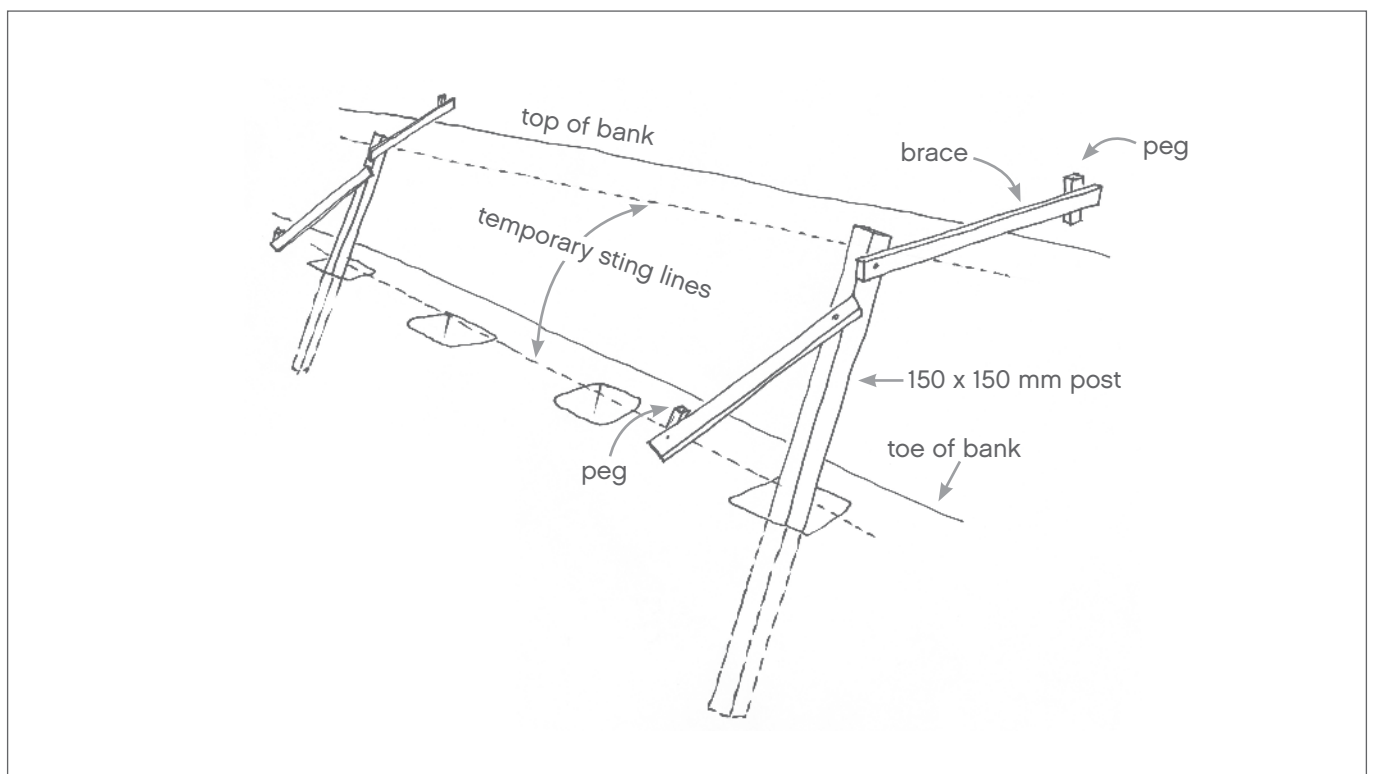
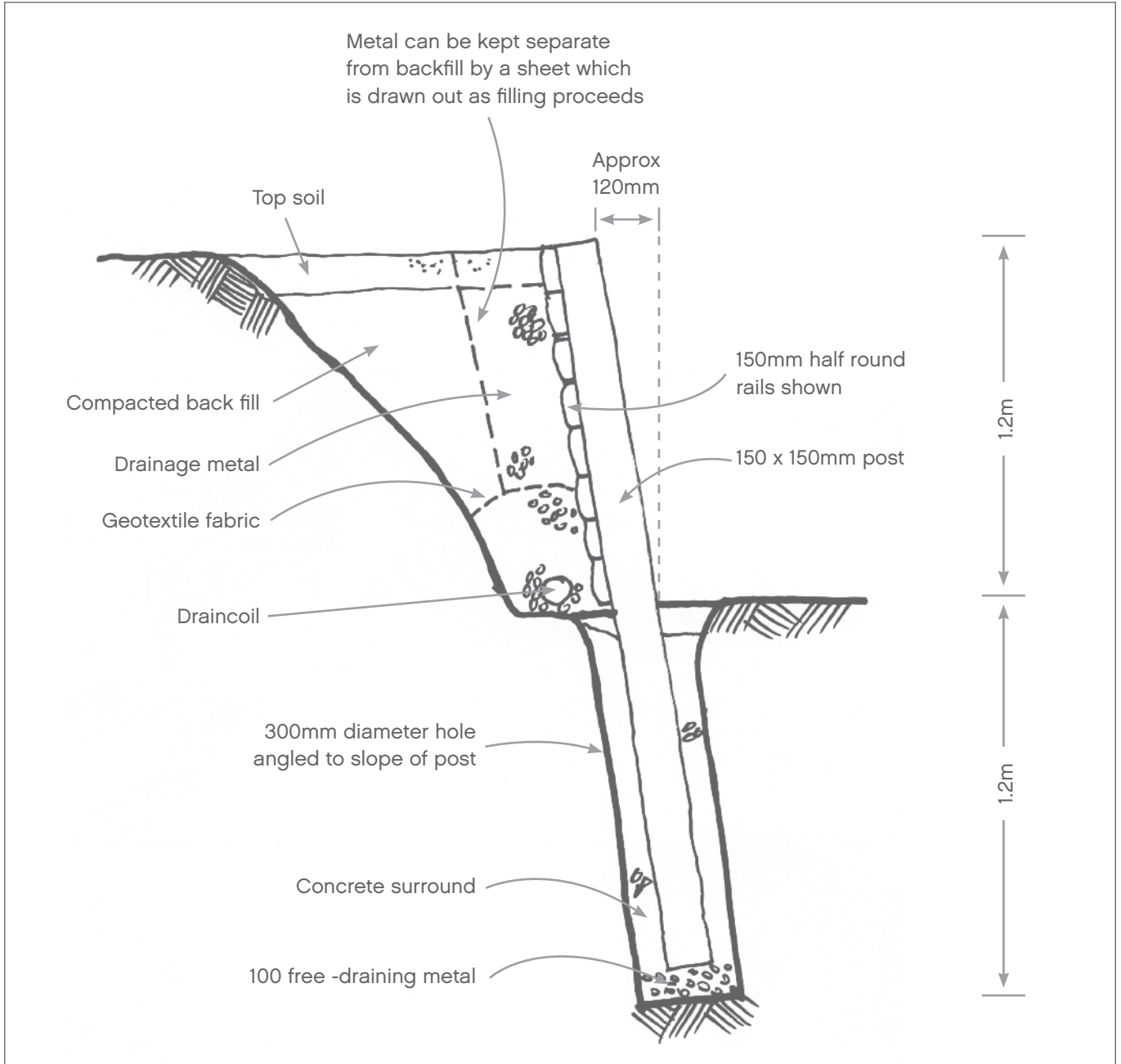

Figure 3



**Disclaimer:**

Woodco has taken reasonable care to ensure that the information and the facts contained on the website are accurate and any opinions given are fair and reasonable.

However, the website makes the information available to you as a general information service only.

The information contained on, or provided through, the website has not been prepared by taking into account the particular objectives, situation or needs of any individual users.

Accordingly, you should assess whether it is appropriate in light of your own objectives, situation and needs.

For that reason Woodco strongly recommends that you confirm any information that relates to a particular product.

Woodco also recommends you consult a professional before proceeding with any project or acting on any of the information or material provided on the website.