



HOW-TO-BUILD GUIDE

TIMBER WINDOWS

WHAT YOU CAN BUILD USING THIS GUIDE

This guide shows you how to install a factory-made timber casement window into a house with a weatherboard cladding. Casement windows typically have side hung (outward opening) sashes and may incorporate a fan light or top light opening sash.

BEFORE YOU BEGIN

You need to consider the durability required of the window and the timber species you choose, construction type and finish.

Under the New Zealand Building Code, windows are required to have a durability of not less than 15 years.

Timber windows in New Zealand have traditionally been made from locally grown softwoods such as: rimu (frames), matai (sills), totara and kauri (sashes), and Californian redwood. As native timbers have become increasingly scarce, other timbers have come into common usage such as:

- western red cedar (imported)
- pinus radiata (both clears and finger-jointed, the latter for paint finish only)
- cypress species such as macrocarpa, Mexican cypress, and Lawson's cypress
- kwila (imported).

A combination of timbers may be used in a window, for example, western red cedar for sashes and pine for frames and sills. The choice of material is largely determined by the type of finish required and the degree of exposure of the window. Joinery will perform better when made from a stable and durable timber such as western red cedar.

Window construction

Mortise and tenon joints are still used as the primary sash stile-to-rail joint for most window types. This involves a tenon, or tongue, from the rail being fitted, glued and pinned into a slot in the stile (Figure 1).

Moisture-cured polyurethane glue, which has good water resistance and retains its flexibility, is generally used for window joints.

Decorative finish

Paint is the recommended finish for exterior windows as it affords the best protection against the effects of ultraviolet light and weathering generally. Semi-transparent and transparent finishes (stains) have limited durability.

BUILDING CODE CONSIDERATIONS

When replacement of a timber window becomes necessary, it has to be done to comply with the performance requirements of the Building Code. The replacement of a window affects the external fabric of the building and obtaining a building consent is recommended.

Timber window installation is not covered by Building Code compliance document E2/AS1 and must be consented as an Alternative Solution. This means that you must demonstrate to your local building consent authority that the detail meets the performance requirements of Building Code Clause E2 *External moisture*.

Provided the existing window has given good service in its setting for years, the replacement by the same detailing (together with the modifications suggested in the Figures) can be used to show compliance with Clause E2.

To obtain a building consent it will be necessary to provide detailed drawings. It is usual to provide scale drawings of the head, sill and jamb, similar to Figures 5, 6, and 7.

DOCUMENTING THE ALTERNATIVE SOLUTION

The following aspects of the replacement window will need to be detailed for consent:

- the treatment of the rough opening to follow the principles of window detailing in E2/AS1
- sill tray flashing
- window head detailing
- perimeter air seal.

Designs to E2/AS1 require the wall underlay to be dressed into all framed openings to protect the timber from any moisture that may get through the other lines of defence. When replacing an existing window this will not be completely possible, however flexible flashing tape must be installed:

- at corners of the window head
- over the full width of the sill and turned up 100 mm at both sides, and
- carried 50 mm down the external face of the cladding.

Under E2/AS1, where the cladding is direct-fixed, a full-width sill tray should be fitted. The sill tray must have:

- a minimum 5° slope
- stop-ends lapped under the jamb packers.

Head flashings under E2/AS1 must have:

- a minimum 15° cross fall
- a minimum 35 mm overlap by the cladding from above
- an additional layer of wall underlay lapped over the flashing or the top edge of the flashing taped to the wall underlay
- 10 mm stop-ends at each end
- a 5 mm anti-capillary gap between cladding and flashing
- a 15 mm downturn over the head

A continuous, flexible air seal over a backing rod should be installed between the wrapped opening and window reveal to limit air flow carrying water into the wall interior.

REPLACEMENT OF A TIMBER WINDOW IN AN EXISTING OPENING

The following example is for a timber window with standard profiles in a timber- framed wall with bevel-backed weatherboard cladding.

Ordering the new window

Since the external weatherproofing is affected, it is usual to order and have the replacement window at hand before the existing window is removed. This will ensure that the building is open to the weather for as little time as possible.

Determine the existing rough opening dimensions and depth of framing. This can be done with removal of the interior architraves and the sill board (Figure 2). Measure the horizontal and vertical openings at the ends and in the middle. Use the smallest dimensions in each case.

Ideally, the joiner will visit the site and take his/her own measurements.

The joiner will need this information:

- window dimensions (rough opening, frame size). The frame size usually allows 6-12 mm clearance to each part of the rough opening (Figure 3).
- profiles for frames, sashes, sill
- wall thickness
- internal lining and external cladding
- type of timber
- required finish (paint, clear)
- glass type
- facing sizes
- which sashes are opening and fixed
- opening hardware type (hinged, friction stays, sliding)
- metal for hardware (stainless steel, brass)
- You will also need to order head and sill flashings.

On delivery of the replacement window, check all sizes, including diagonals.

Removal of the existing window

On the exterior, remove the head flashing. This may require the weatherboard above the head to be eased up. Do this carefully to avoid splitting the board. In cases where nails penetrate the flashing, they will need to be cut with a metal keyhole saw. Remove facing boards, scribes, and any trim below the sill.

Remove any opening sashes, as this will reduce the weight of the window and make handling easier.

The frame will usually be fixed by nails through the jamb, at positions near the top and bottom. Locate these fixings (often shown by the jamb packers). Release these fixings, either by cutting through in the gap between the frame and trimmer stud, or by driving the nail fully through the frame.

With the fixings released, the frame should be able to be removed from the exterior. You may need assistance if the window is larger than a single casement.

Preparation of the window for the opening

Generally the frame will come with mitred corners at the head and no trimming is required. The sill will need to be scribed to fit against the weatherboards. This can be done by:

- fitting the frame into the opening as close as possible to the final position with the sill at the correct height and scribing the sill, or
- tacking a batten on to the weatherboards in place of the facing board and taking sufficient measurements so that the sill can be cut (Figure 4).

Preparation of the opening

Inspect the opening for any sign of moisture or fungi that indicate that water has been getting in. This will show if the existing detailing has been inadequate.

In the replacement of a window, where the cladding is already in place, this places a restriction on what can be achieved. In most cases the wall wrap will have been trimmed to the edges of the opening.

If there are no signs of leaks, it is recommended that the cladding is left undisturbed and the flexible flashing tape is installed to provide an overlap to the cladding itself. Figures 5, 6, and 7 show recommendations for the installation of flexible tape in an opening where the cladding is already installed.

Supporting blocks for the sill can be positioned at each end. While not essential, it is recommended that an additional fillet be placed on the bottom of the rough opening. It will assist in the placement of the flexible tape.

It is recommended that photographs are taken of the prepared opening for your records and possibly for showing building inspectors. A council inspection may be required before the window is inserted.

The sill flashing can now be measured for the existing opening, provided with upstands at the ends and put into place.

The frame can be lifted into position, levelled, and the jambs plumbed. Insert jamb packers at the fixing points. Nail or screw through the frame to secure the frame to the trimming stud.

E2/AS1 allows the top of the flashing upstand to be taped to the wall underlay which may be able to be achieved as the weatherboard immediately above the window is likely to have been prised out or removed to allow the removal of the existing flashing. Where this is not possible, fit the head flashing with a liberal bead of silicone sealant along the top edge of the back face of the upstand and press it firmly back onto the wall underlay.

Fit the facing boards, and scribes. A cover bead should be provided below the sill.

On the interior, fit the sill board and architraves and hardware.

FURTHER INFORMATION

New Zealand Building Code E2/AS1 (available for download free from www.dhb.govt.nz)

BRANZ Bulletin 481 *Timber windows*.

NZS 3602 *Timber and wood-based products for use in building*. This standard identifies the timbers and treatments permitted for windows and frames.

NZS3610 *Specification for profiles of mouldings and joinery*.

Figure 1 – Mortise and tenon joint

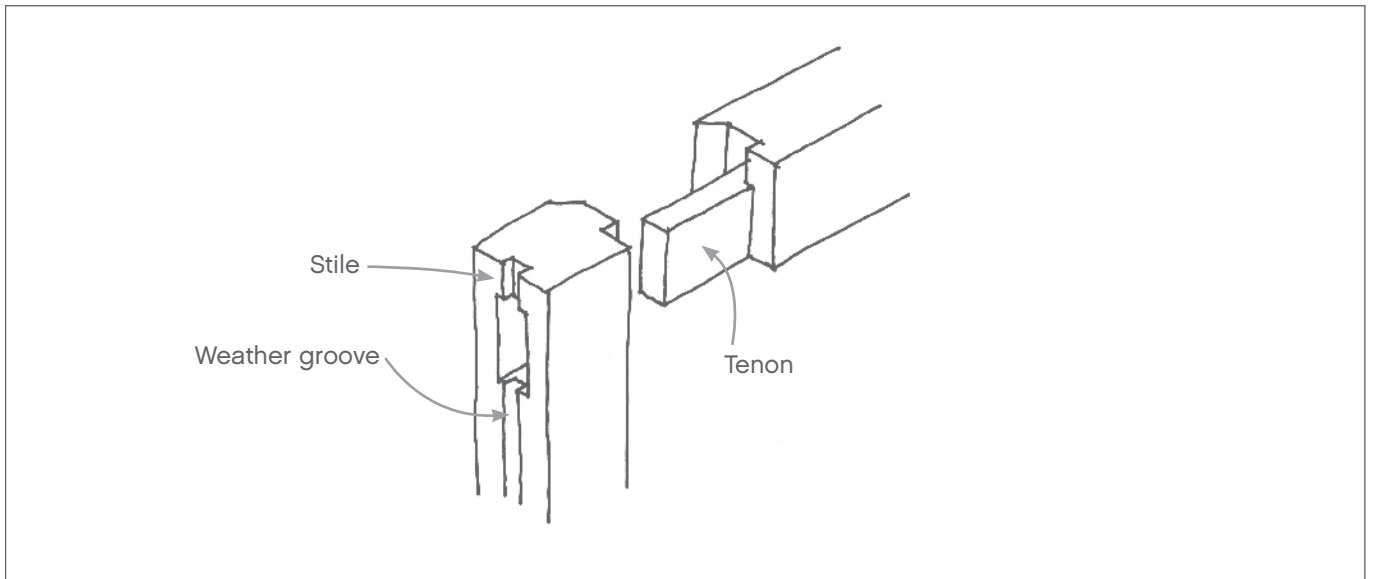

Figure 2

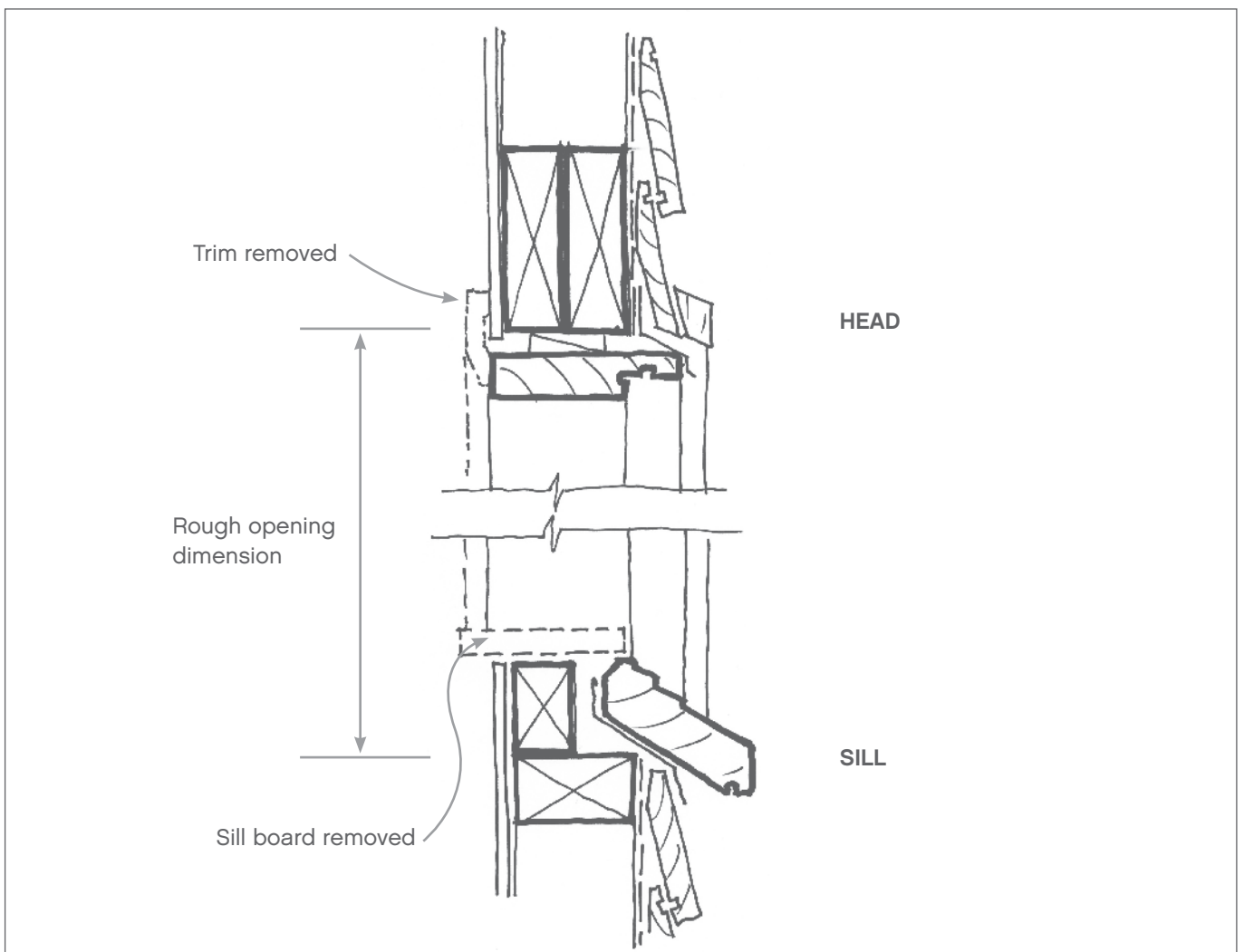

Figure 3

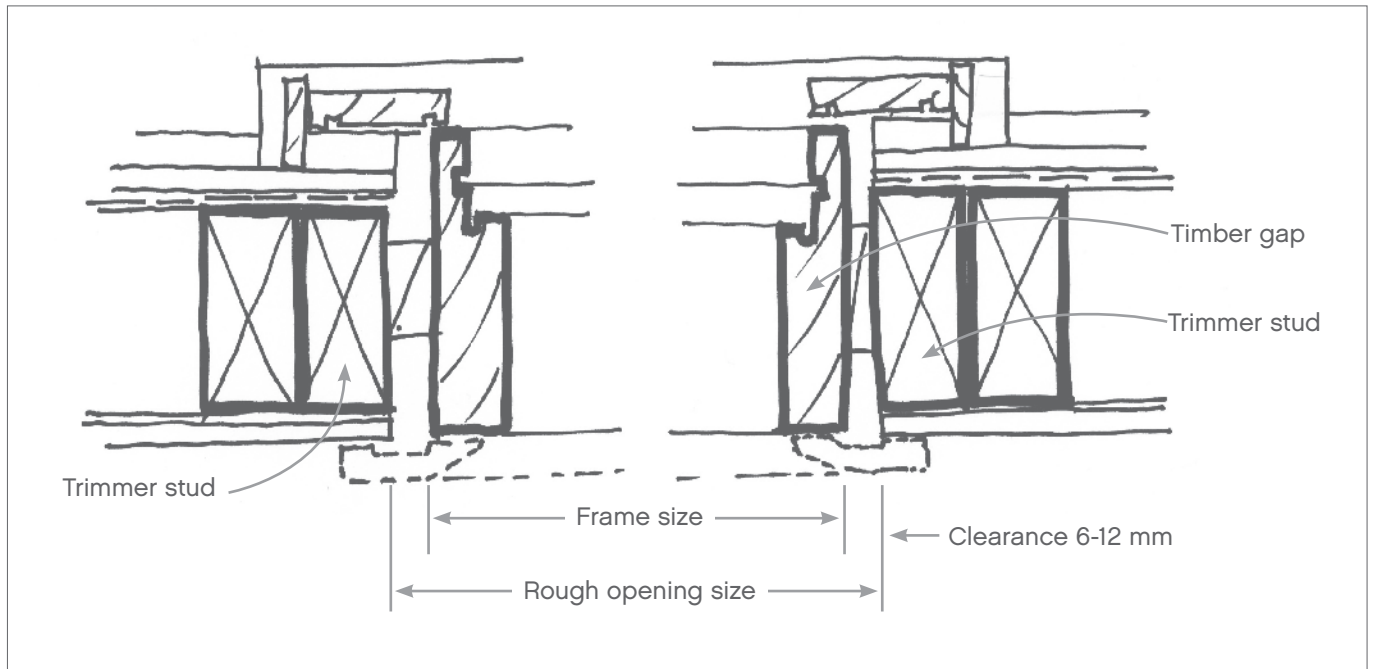

Figure 4

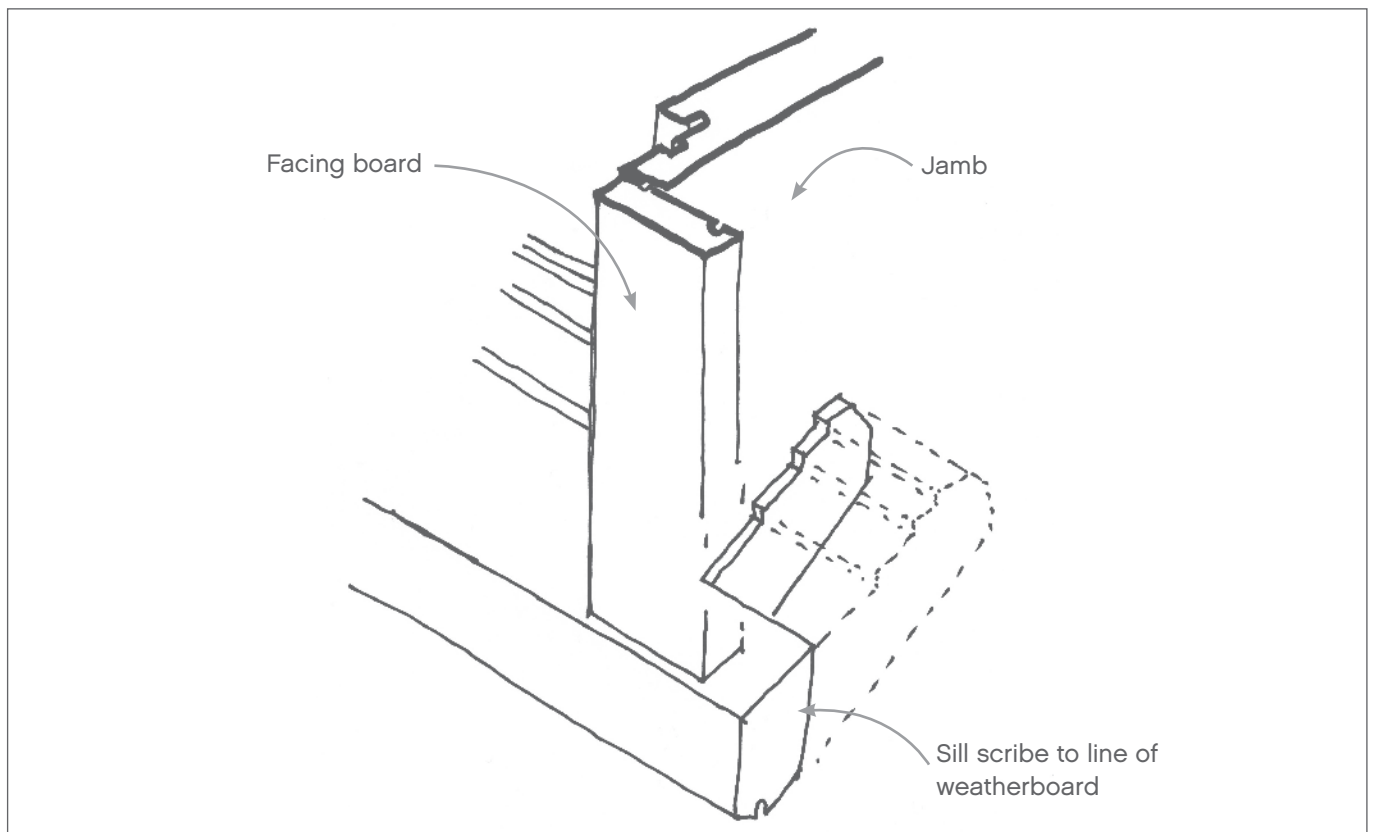

Figure 5

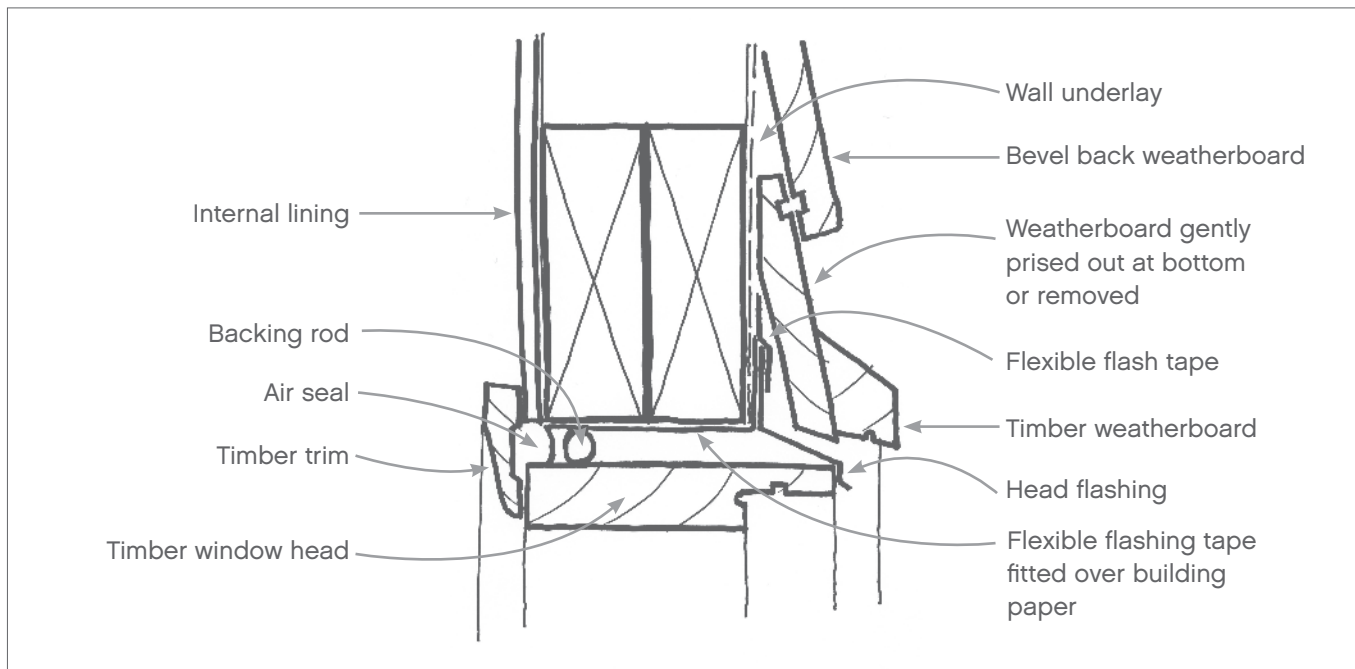

Figure 6

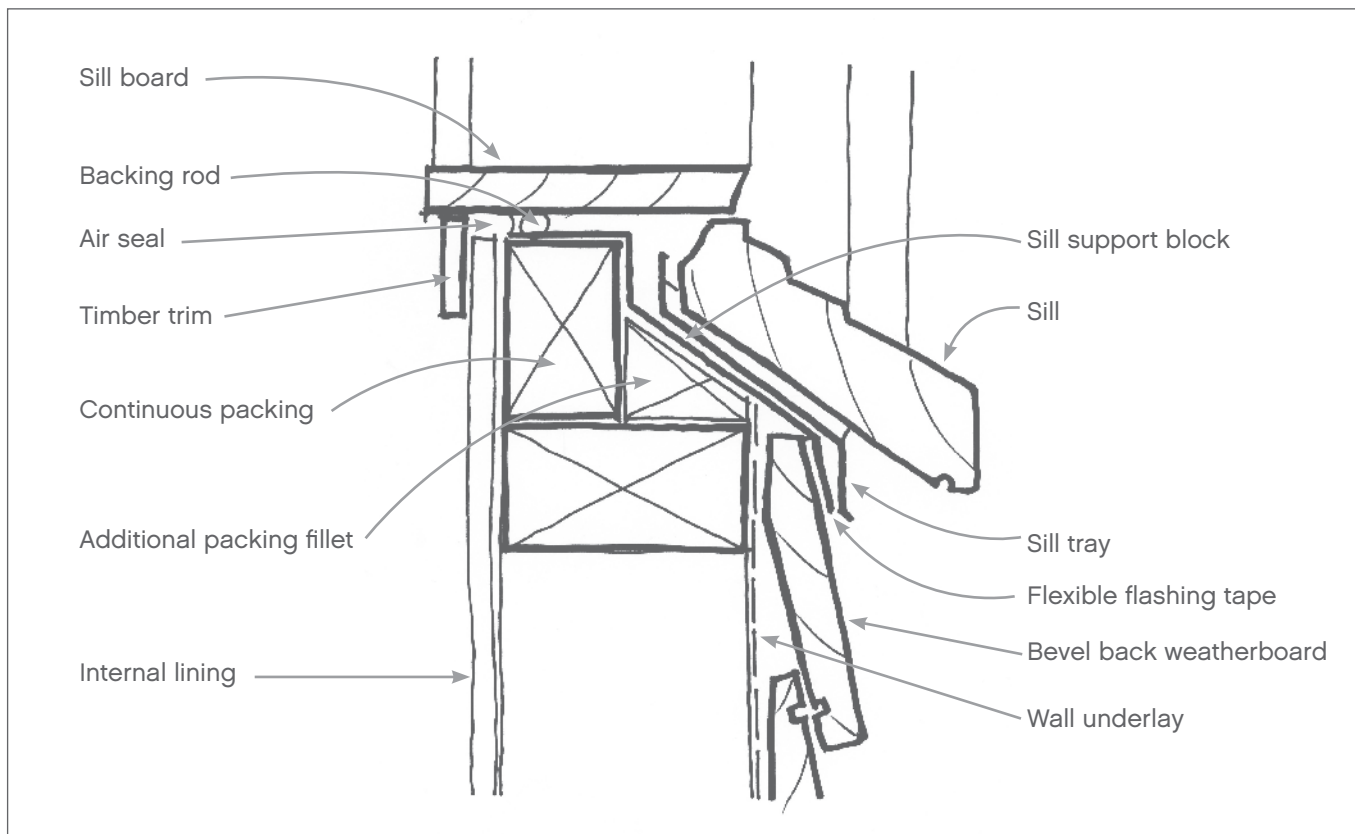
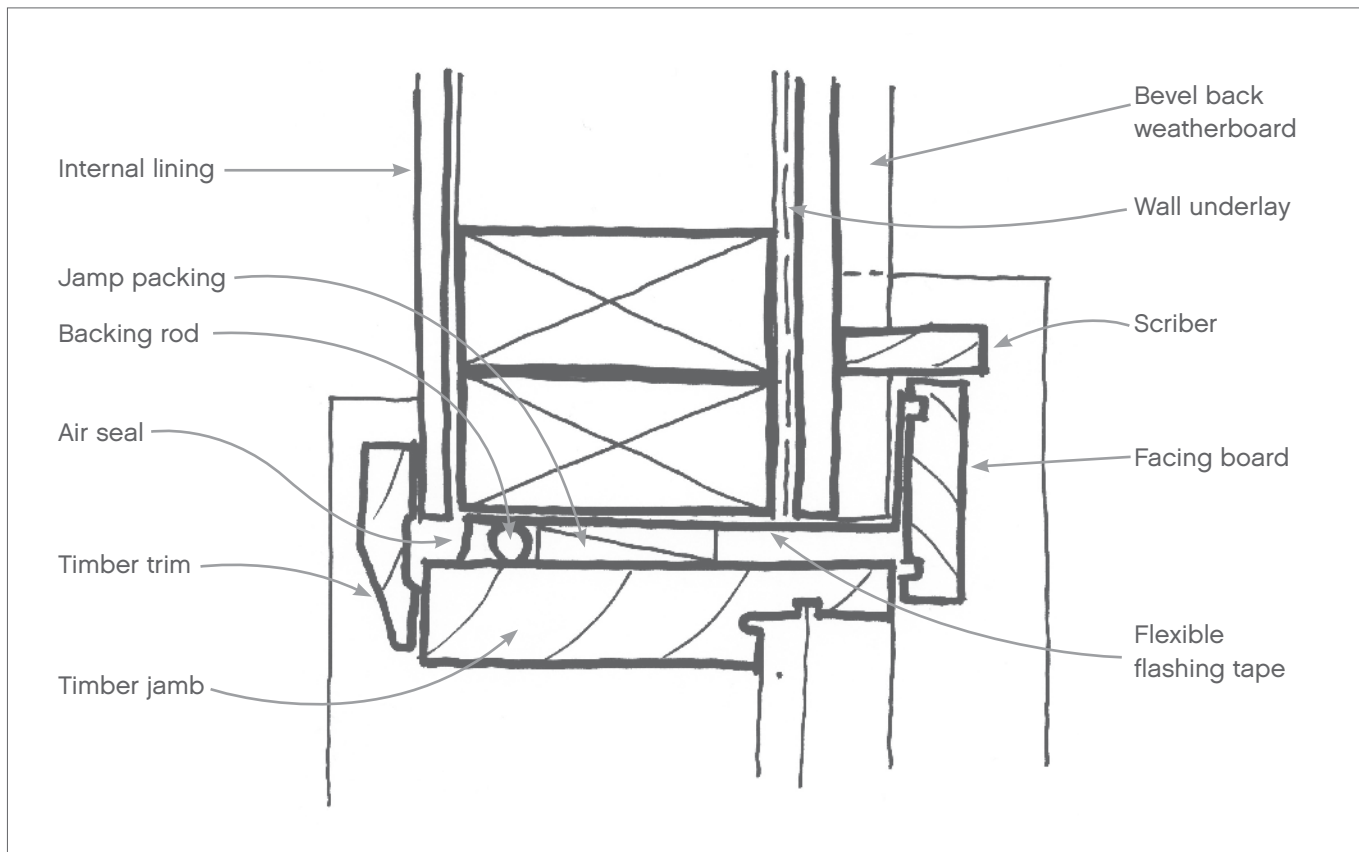

Figure 7 – Jamb



Disclaimer:

Woodco has taken reasonable care to ensure that the information and the facts contained on the website are accurate and any opinions given are fair and reasonable.

However, the website makes the information available to you as a general information service only.

The information contained on, or provided through, the website has not been prepared by taking into account the particular objectives, situation or needs of any individual users.

Accordingly, you should assess whether it is appropriate in light of your own objectives, situation and needs.

For that reason Woodco strongly recommends that you confirm any information that relates to a particular product.

Woodco also recommends you consult a professional before proceeding with any project or acting on any of the information or material provided on the website.